

RESIN / WAX MINIMUM FEATURE SIZE

Text Sizing for SLA

Please ensure all details are above these dimensions. When text is embossed we recommended 0.50mm high because it can be taken back once built.

Note: These are the minimum recommended sizes when building in Resin or Wax.

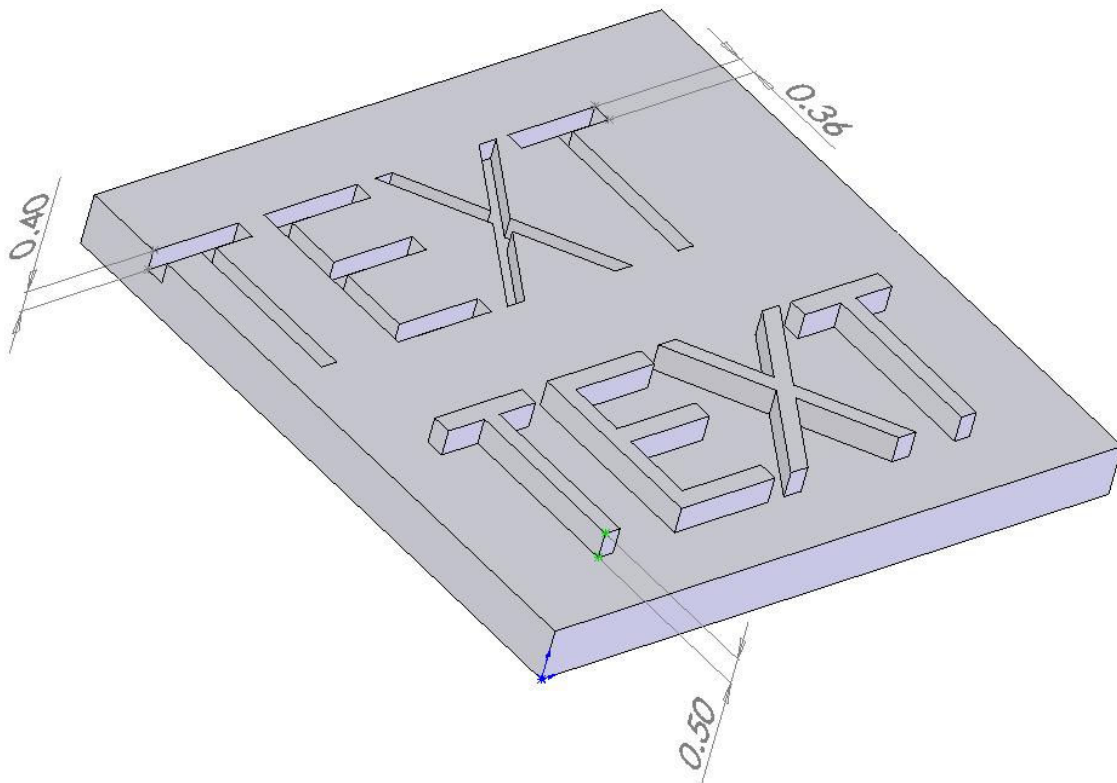

Contact us for more information t. 02 9557 9468. e. info@rapidprototype.com.au
We look forward to hearing from you.